

# Model T1 Torque Coupling Rotary Torque Transducer

Why the Interface model T1 Torque Coupling Rotary Torque Transducer is the best in class:

- Capacities from 50 to 1K Nm (442 to 8,850 lb-in)
- Shortest installed length
- Integrated double-flex disc coupling
- Hollow
- Bearingless non-contact design
- ±15 bit resolution
- 10 kHz sample rate
- ±5 VDC output
- 16-bit resolution

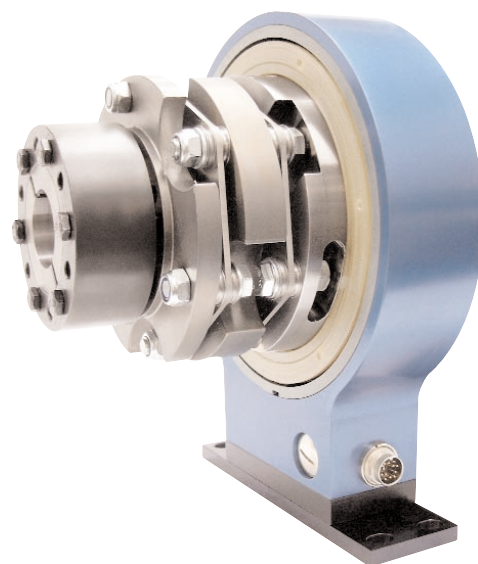

T1 Torque Coupling Rotary Torque Transducer  
Shown with standard shrink-disk hub

## OPTIONS

Enhanced Accuracy - 0.05%  
High RPM  
Speed Measurement - 30 Pulse +5V TTL  
±10 VDC Output  
RS485

## SPECIFICATIONS

ACCURACY – (MAX ERROR)	Standard	Enhanced
Combined Error-% FS	±0.15	±0.05
Nonrepeatability-%	±0.02	±0.005
<b>TEMPERATURE</b>		
Effect on Zero-% RO/°C	±0.02	±0.008
Effect on Output-%/°C	±0.01	±0.005
Rated Range-°C	+5 to +45	
Operating Range-°C	0 to +60	
<b>ELECTRICAL</b>		
Output-VDC	±5	
Bandwidth, Hz	3 kHz-3dB	
Sample Rate	10 kHz	
Calibration Signal-% FS	100	
Supply Voltage-VDC	12 to 18	
Supply Current-mA	<100	
Electrical Connection	12-pin	
Resolution	16-bit	
<b>MECHANICAL</b>		
Safe Overload-% RO	200	
Cyclic Load Rating-% RO	±70 peak	
Ultimate Overload-% RO	300	
Max Speed-rpm	13.6K-See Table	

**T1 Torque Coupling Rotary Torque Transducer - Capacities 50 to 1K Nm**

**DIMENSIONS**

Size (mm)	AS	AR	AP	B	C	C1	dA*	dS*	dR*	dP*	dG*	E	F	G	H	L	L1
16	53	73	50	77	134.2	129.2	14-26	14-26	25-35	16-32	30-45	64	117	184	134	40	35
25	64	84	60	89	139.4	134.4	20-36	20-36	30-40	20-40	35-55	68	122.5	195	145	45	40
40	74	97	70	104	153.8	143.8	25-45	24-45	30-45	25-50	45-65	68	130.5	211	161	55	45
64	84	115	80	123	170.2	155.2	30-45	30-45	35-55	30-55	55-75	68	140	230	180	65	50
100	104	135	100	143	181	161	35-55	35-55	40-68	35-70	65-95	68	150	250	200	75	55

\*Dimensions are min.-max.

Dimensions in mm

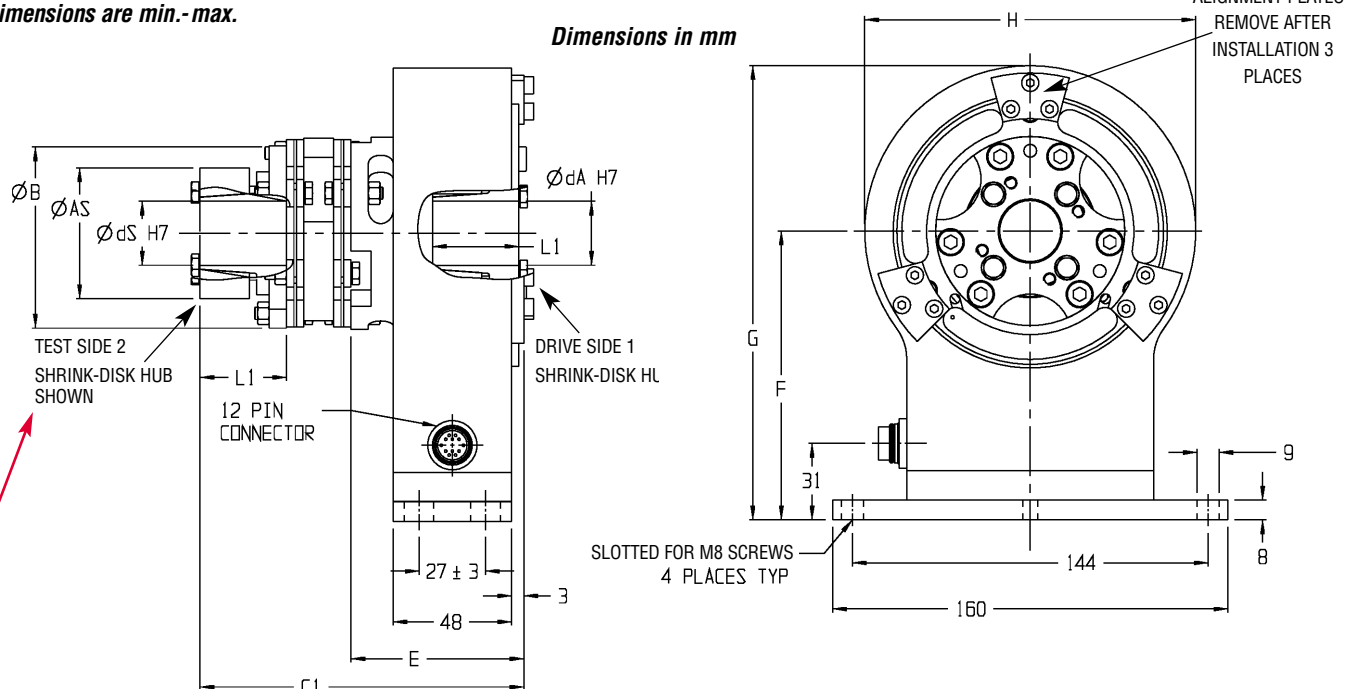

HUB OPTIONS FOR SIDE 2

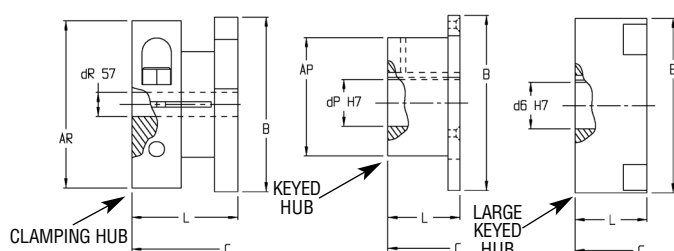

SIZE	Nominal Torque		Max. Revolution		*Max. Axial Load	*Axial Displcmnt Max. (mm)	*Angular Displcmnt Max. (°)	*Radial Displcmnt Max. (mm)	Springrate (Nm/rad)	Moment of Inertia (kg m <sup>2</sup> )	
	Nm	lb-in	Standard	Extended						Side 1	Side
16 (E)	50	443	6,800	13,600	150	0.25	0.05	6.3E+04	2.1E-03	1.0E-03	
	100	885									
	150	1.33K									
25 (F)	150	1.33K	5,900	11,800	190	0.25	0.05	1.3E+05	4.0E-03	1.8E-03	
	200	1.77K									
	250	2.21K									
40 (G)	200	1.77K	5,000	10,000	250	0.3	0.06	1.5E+05	6.4E-03	3.7E-03	
	300	2.66K									
	400	3.54K									
64 (H)	400	3.54K	4,300	8,500	450	0.3	0.06	3.6E+05	9.3E-03	8.5E-03	
	500	4.43K									
	600	5.31K									
100 (J)	600	5.31K	3,700	7,300	600	0.45	0.07	5.5E+05	1.9E-02	1.6E-02	
	750	6.64K									
	1K	8.85K									

\*Single values may not reach the maximum values simultaneously. Moments of inertia apply to clamping hub at largest bore.