

INSTALLATION INFORMATION

- Interface 1000, 1100, 1200 Series Load Cells must be mounted on a surface that is flat and rigid enough so as not to deform appreciably under load. An easy way to obtain the flat rigid surface is by using an Interface supplied base or mounting plate. Where this is not practical, a rigid surface equivalent to the appropriate Interface base or mounting plate will suffice. Interface load cells respond to forces in the axis perpendicular to the mounting surface. Load cell response to a non-axial force is proportional to that force times the cosine of the angle it makes with the loading axis.
 - When installing these load cells without factory-installed Interface base or bottom plate, the Grade 8 cap screws holding the cell to the mounting plate must be tightened to the value shown in Table 3 or 4 on Page 2.
 - 3200 Series Stainless Steel Load Cells have the same mounting dimensions and parameters, except "C" dimension on Page 2, as 1200 Series.
 - 1000 Series Load Cells must have jam nuts tightened to the value shown in Table 3 on Page 2, to avoid thread damage.
 - For the best performance of Series 1100 and 1200 Load Cells, the use of jam nuts is recommended. The jam nuts should be installed and torqued as indicated in Table 3 on Page 2.
 - Rod end bearings, or threaded adapters, should have smooth threads and class 3 fit*. They should be installed hand tight and backed off 1 turn prior to tightening jam nut as indicated in Table 3 on Page 2.
 - Bearing Plates should be hardened steel (Rc 45 or higher) when mating with a load button or steel load cells. For aluminum compression-only load cells, a mild steel bearing plate may be used.
 - To eliminate potential reading errors, the outer rim or base of the load cell and its connecting electrical cable should be mounted on the fixed or non-moving structure.
- *Class 6g Metric.

TYPICAL INSTALLATIONS

TENSION

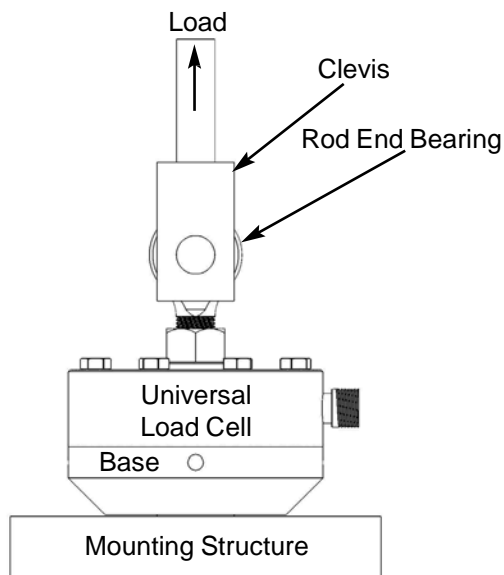

Installation on irregular structure surface using Interface base.

COMPRESSION

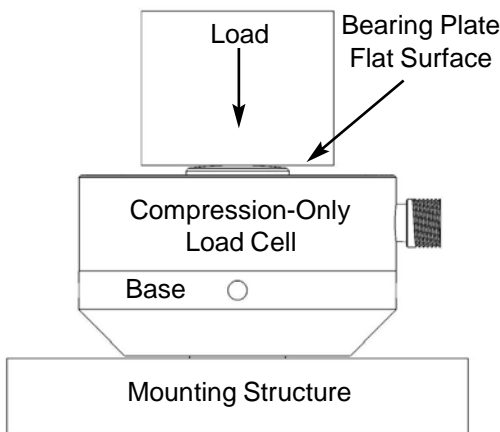

ROD END MOUNTING

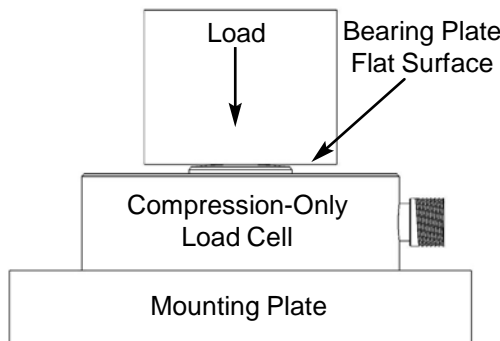
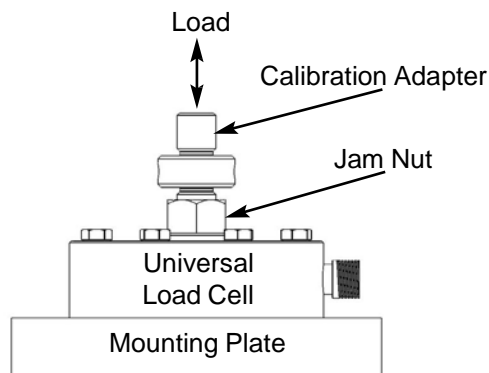
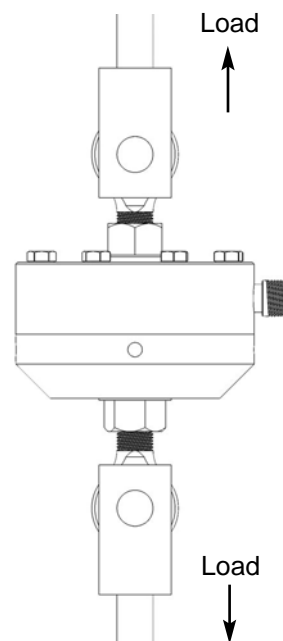

Installation on flat plate per Table 1 or 2 on Page 2 and perpendicular to load axis within 1 degree. Flexure mounting screws to be tightened to the value shown in Table 3 or 4 on Page 2.

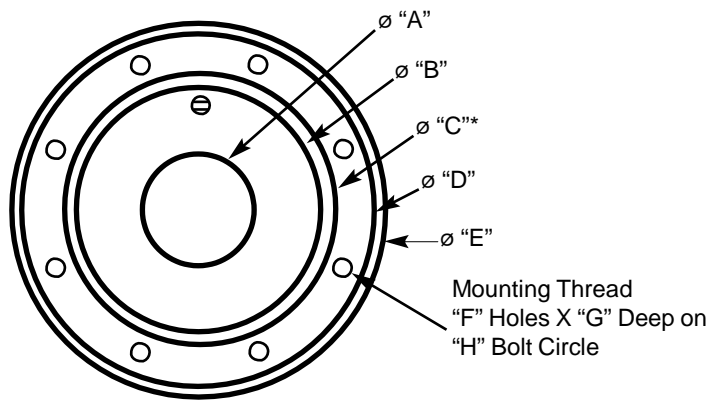

1. Interface bases are heat-treated to a Rockwell hardness of 30-33.
2. Mounting surface should be perpendicular to the load axis within 1 degree.
3. Mounting screws should be Grade 8 (10.9) or better.
4. Torque, lightly lubricated, mounting screws per Table 3 or 4 below.
5. Inner and outer rings identify the critical area over which flatness specification applies.
- *6. Increase "C" diameter by 0.15 for 3200 Series Stainless Steel Load Cells.

Table 1 - Base or Mounting Plate Dimensions, Universal Load Cells

Model Number	Hub Diameter "A"	Inner Mounting Ring		Outer Mounting Ring		Mounting Threads				Mtg Surface Flatness
		"B"	"C"	"D"	"E"	Thread	"F"	"G"	"H"	
1010, 1X10	1.34	2.87	3.14	3.98	4.13	1/4-28	8	0.30	3.500	0.0002
1020, 1X20	2.65	3.99	4.54	5.84	6.06	3/8-24	12	0.63	5.125	0.0002
1032, 1X32	3.76	5.47	5.75	7.80	8.00	1/2-20	16	1.00	6.500	0.0002
1040, 1X40	4.81	6.76	7.42	10.58	11.00	5/8-18	16	1.12	9.000	0.0002
1044, 1244	4.81	6.76	7.42	10.58	11.00	3/4-16	16	1.20	8.750	0.0002
1050, 1250	5.80	7.55	8.55	11.30	12.00	3/4-16	20	1.30	9.500	0.0004
1060, 1260	7.68	9.90	11.05	14.65	15.50	7/8-14	24	1.50	12.684	0.0004
1080, 1280	10.55	13.17	14.49	19.60	20.50	1.00-14	28	1.60	16.500	0.0010
1090, 1290	N/A	16.16	18.15	24.65	26.00	1 1/4-12	32	2.00	20.500	0.0010

Table 2 - Base or Mounting Plate Dimensions, Compression-Only Load Cells

Model Number	Hub Diameter "A"	Inner Mounting Ring		Outer Mounting Ring		Mounting Threads				Mtg Surface Flatness
		"B"	"C"	"D"	"E"	Thread	"F"	"G"	"H"	
1X11	1.34	2.87	3.14	3.98	4.13	1/4-28	8	0.30	3.500	0.0002
1221	1.57	3.15	3.42	4.58	4.75	5/16-24	4	0.50	4.000	0.0002
1121	2.65	3.99	4.54	5.84	6.06	3/8-24	12	0.63	5.125	0.0002
1231	3.13	5.00	5.40	7.25	7.50	7/16-20	12	0.75	6.250	0.0002
1241	3.16	5.11	5.74	7.73	8.25	5/8-18	12	1.00	6.750	0.0002
1243	4.81	6.76	7.42	10.58	11.00	5/8-18	16	1.20	9.000	0.0002

Table 3 - Mounting Parameters, Universal Load Cells

Model Number	Capacity		Mounting Screw Size		Mounting Screw Torque		Thread Adapter Torque		Max. Hub Torque	
	US (lbf)	Metric (kN)	Fractional	Metric	(lb-ft)	(Nm)	(lb-ft)	(Nm)	(lb-ft)	(Nm)
1X10	300	1.5	1/4-28 UNF X 1.50	M6 X 40mm	5	7	10	14	10	14
1010, 1X10	250, 500	1.25, 250	1/4-28 UNF X 1.50	M6 X 40mm	5	7	15	20	16	20
1010, 1X10	500, 1K	2.5, 5	1/4-28 UNF X 1.50	M6 X 40mm	5	7	25	34	32	43
1010, 1X10	1K, 2K	5, 10	1/4-28 UNF X 1.50	M6 X 40mm	5	7	50	68	65	88
1010, 1X10	2.5K, 5K	12.5, 25	1/4-28 UNF X 1.50	M6 X 40mm	10	14	100	136	165	224
1010, 1X10	5K, 10K	25, 50	1/4-28 UNF X 1.50	M6 X 40mm	10	14	100	136	330	445
1020, 1X20	12.5K, 25K	50, 100	3/8-24 UNF X 2.25	M10 X 60mm	55	75	Pull thread adapter to 110-140% of capacity and tighten jam nut.	830	1130	
1020, 1X20	25K, 50K	125, 250	3/8-24 UNF X 2.25	M10 X 60mm	55	75		1660	2250	
1032, 1X32	50K, 100K	225, 450	1/2-20 UNF X 3.00	M12 X 75mm	120	160		3320	4500	
1040, 1X40	100K, 200K	450, 900	5/8-18 UNF X 4.00	M16 X 100mm	250	340		6640	9000	
1044, 1244	135K, 270K	600, 1200	3/4-16 UNF X 4.50	M20 X 115mm	350	475		9000	12200	
1050, 1250	200K, 400K	900, 1800	3/4-16 UNF X 5.50	M20 X 140mm	400	540		13300	18000	
1060, 1260	300K, 600K	1500, 2700	7/8-14 UNF X 6.40	M24 X 165mm	640	870		20000	27000	
1080, 1280	500K, 1000K	2250, 4500	1.00-14 UNS X 7.50	M24 X 190mm	1150	1560		33300	45000	
1090, 1290	1000K, 2000K	4500, 9000	1 1/4-12 UNF X 9.50	M30 X 250mm	2000	2700		66600	90000	

Table 4 - Mounting Parameters, Compression-Only Load Cells

Model Number	Capacity		Mounting Screw Size (Socket Head Cap Screw)	Mounting Screw Torque	
	US (lbf)	Metric (kN)		(lb-ft)	(Nm)
1X11	1K, 2K	5, 10	1/4-28 UNF X 1.25	5	7
1X11	5K, 10K	25, 50	1/4-28 UNF X 1.25	10	14
1221	25K, 50K	125, 250	5/16-24 UNF X 1.75	25	34
1121	25K, 50K	125, 250	3/8-24 UNF X 1.75	55	75
1231	100K	450	7/16-20 UNF X 2.00	80	110
1241	200K	900	5/8-18 UNF X 3.00	250	340
1243	400K	1800	5/8-18 UNF X 3.50	250	340